

LIBRARY HANUSARO  
SECRETARY.



REPUBLIC OF NAURU

# Government Gazette.

*Published by Authority*

No. 32.

25th May, 1983.

Nauru.

G.N.No.271/1983.

## PROCLAMATION

### REPUBLIC OF NAURU

#### Prorogation of Parliament - Article 41(1) of the Constitution

Pursuant to Article 41(1) of the Constitution, I, R.J.T. Kun, Speaker of Parliament, in accordance with the advice of His Excellency the President, hereby prorogue Parliament this 23rd day of May, 1983.

Dated this 23rd day of May, 1983.

R.J.T. KUN  
SPEAKER

G.N.No.272/1983.

### PUBLIC SERVICE ACT 1961-1979

#### VACANCY : SECTION 20

Applications are invited from Nauruans both inside and outside the Public Service for appointment, promotion or transfer to the following position:-

#### DEPARTMENT OF HEALTH & EDUCATION

(Directorate of Health)

Position: Executive Officer

Salary: \$9540 - 10,980 p.a. (AP6/7)

Duties: Responsible to the Director of Health and Medical Services for the Dispensary, Personnel matters, Travel arrangements, Budgeting and Accounting, Stores Control including ordering, Departmental Motor Transport, Building Maintenance.

G.N.No.272/1983 (Cont'd).

Qualifications: Extensive experience of at least 10 years in the management of a big office dealing with duties specified above, recognised diploma or certificate in administrative management preferred, good command in written English an additional advantage.

Applications should be lodged in writing stating name, age education qualifications and experience with the Chief Secretary before 4.30 p.m. Friday 3rd June, 1983.

Dated this 19th day of May, 1983.

T.W. STAR  
PUBLIC SERVICE COMMISSIONER

G.N.No.273/1983.

REPUBLIC OF NAURU

PUBLIC SERVICE ACT 1961 - 1979

NOTICE OF PROVISIONAL PROMOTION

The following provisional promotion with effect from 19th May, 1983 is hereby notified:-

DEPARTMENT OF WORKS AND COMMUNITY SERVICES

<u>NAME</u>	<u>PROMOTED FROM</u>	<u>PROMOTED TO</u>
DAME, Donald	Plant Operator \$5172-\$5772 p.a. (T1/T2)	Leading Hand Plant Section \$6216-\$6504 p.a. (T.4)

Any officer of the Public Service may appeal against the above promotion as provided for under Section 25 of the Public Service Act. Appeals should be based on one or other of the grounds set out in Section 25(2) and should be lodged in writing, stating the grounds of appeal, with the Public Service Commissioner within seven (7) days after the date of this Gazette.

Dated this 19th day of May 1983.

T.W. STAR  
PUBLIC SERVICE COMMISSIONER

G.N.No.274/1983.

Determination of the Beneficiaries of the Estate of the late Baden Inia of Buada District.

E S T A T E

1. The Nauru Lands Committee has ascertained that the late Baden Inia had been determined by the decisions of the Nauru Lands Committee (or its predecessor the Lands Committee to be the owner of the following lands:-

District	Portion No.	Type of Land	Name of Land	Gazette Notice of Ownership	Share
Aiwo	2	P.L.	Abaruworuw	35/69	1/4
Aiwo	131	C.L.	-	35/69	1/4
Aiwo	316	P.L.	-	35/69	1/4
Aiwo	463	P.L.	Aniwio	35/69	1/4
Buada	9	P.L.	Metub	35/69	1/4
Buada	74	P.L.	Atero	35/69	1/4
Buada	82	P.L.	Ijuae	35/69	1/4
Buada	290	P.L.	Eatebaranuinae	35/69	1/4
Buada	321	C.L.	Ata	35/69	1/4
Buada	336	C.L.	Anoreo	35/69	1/4
Buada	359	C.L.	Edunawurung	36/81	1/4
Denigomodu	31	C.L.	Atowedudu	35/69	1/4
Denigomodu	99	C.L.	-	35/69	1/4
Denigomodu	131	C.L.	Atumurumur	35/69	1/4
Denigomodu	132	C.L.	Atumurumur	35/69	1/4
Denigomodu	151	C.L.	Atumurumur	35/69	1/4
-do-	205	C.L.	-do-	35/69	1/4
-do-	206	C.L.	-do-	35/69	1/4
-do-	207	C.L.	-do-	35/69	1/4
-do-	212	C.L.	-do-	35/69	1/4
-do-	213	C.L.	-do-	35/69	1/4
-do-	220	P.L.	-do-	35/69	1/4
Anibare	146	P.L.	Anotsiya	35/69	1/12
Anibare	148	P.L.	Anotsiya	35/69	1/12
Denigomodu	9	C.L.	Denigomodu	35/69	1/12

G.N.No.275/1983.

DETERMINATION OF BENEFICIARIES

2. The Nauru Lands Committee has determined that the beneficiaries of the estate of the late Baden Inia are:-

(a) in respect of the land shown in paragraph 1 above :

G.N.No.275/1983. (Cont'd)

District	Portion No	Name of Land	Beneficiaries	Share
Aiwo	2	Abaruworuw	Tars B. (LTO)	1/8
		Inia K. T/ee	(Farrah Rossanie Inia	1/8
Aiwo	131	-	As for portion 2 p.l. Aiwo	
Aiwo	316	-	-do-	
Aiwo	463	Aniwio	-do-	
Buada	9	Metub	-do-	
Buada	74	Atero	-do-	
Buada	82	Ijuae	-do-	
Buada	290	Eatebaranuinae	-do-	
Buada	321	Ata	-do-	
Buada	336	Anoreo	-do-	
Buada	359	Edunawarung	-do-	
Denigomodu	31	Atowedudu	-do-	
Denigomodu	99	-	-do-	
Denigomodu	131	Atumurumur	-do-	
Denigomodu	132	Atumurumur	-do-	
Denigomodu	151	Atumurumur	-do-	
Denigomodu	205	Atumurumur	-do-	
Denigomodu	206	Atumurumur	-do-	
Denigomodu	207	Atumurumur	-do-	
Denigomodu	212	Atumurumur	-do-	
Denigomodu	213	Atumurumur	-do-	
Denigomodu	220	-	-do-	
Anibare	146	Anotsiya	Tars B. Inia (LTO)	1/24
		Inia K. T/ee	(Farrah R. Inia	1/24
Anibare	148	Anotsiya	As for portion 146 p.l. Anibare.	
Denigomodu	9	Denigomodu	-do-	

Any person who is dissatisfied with the determination of this estate may appeal to the Supreme Court within 21 days of the publication of this Gazette.

Dated this 22nd February, 1983.

(J.A. DAGUAPE),  
VICE CHAIRMAN.

G.N.No.276/1983.

Determination of the Beneficiaries of the Estate of the late Hercules Akeyman of Baiti District.

E S T A T E

1. The Nauru Lands Committee has ascertained that the late Hercules Akeyman had been determined by the decisions of the Nauru Lands Committee (or its predecessor the Lands Committee to be the owner of the following lands :-

District	Portion No.	Type of Land	Name of Land	Gazette Notice of Ownership	Share
Buada	172	p.l.	Atenani	36/68	1/4
Baiti	19	p.l.	Metub/Adeta	48/55	1/5
Baiti	119	c.l.	Agoro	36/68	1/16
Baiti	148	c.l.	Mwiruru	36/68	1/16
Baiti	195	p.l.	Anakawiduwa	36/68	1/16
Baiti	196	p.l.	Anoror	36/68	1/16
Baiti	205	p.l.	Eatetedij	36/68	1/16
Ewa	4	c.l.	Anora	52/79	1/16
Ewa	57	p.l.	Abaraiami	28/72	1/16
Uaboe	56	p.l.	Yapiyuw	36/68	1/16
Anibare	21	c.l.	Areteng	23/70	1/48
Anibare	23	c.l.	Merubo	23/70	1/48
Anibare	27	c.l.	Merubo	23/70	1/48
Anibare	343	c.l.	Arateng	23/70	1/48
Ewa	148	c.l.	Bogetirir	23/70	1/48
Anibare	199	p.l.	Ibogetiw	11/73	1/80
Anibare	216	p.l.	Irotsin	36/68	1/80
Anibare	218	p.l.	Atekapara	36/68	1/80
Ewa	166	c.l.	Anna	36/68	1/96

G.N.No.277/1983.

DETERMINATION OF BENEFICIARIES

2. The Nauru Lands Committee has determined that the beneficiaries of the estate of the late Hercules Akeyman are:-

(a) in respect of the land shown in paragraph 1 above :

District	Portion No	Name of Land	Beneficiaries	Share
Buada	172	Atenani	Gloria K. Harris	1/8
			Eimoniba Teimiti	1/24

G.N.No.277/1983. (Cont'd)

		Martina Ika	1/24	
		Emoniba Teimiti	1/240	
		Lucas Mervin Hedmon	1/240	
		Lucia Margareth Hedmon	1/240	
		Juliana Eiriogin Hedmon	1/240	
		Virginia Mimosa Hedmon	1/240	
		Virginia Pelsina Hedmon	1/240	
		Eimirien Sophia Hedmon	1/240	
		Linus Hedmon	1/240	
		Liana Margareth Hedmon	1/240	
		Eidogidogaiy Hedmon	1/240 (LTO)	
Baiti	19	Metub or Adeta	Gloria K. Harris	1/10
			Eimoniba Teimiti	1/30
			Martina Ika	1/30
			Eimoniba Teimiti	1/300
			Lucas M. Hedmon	1/300
			Lucia M. Hedmon	1/300
			Juliana E. Hedmon	1/300
			Virginia M. Hedmon	1/300
			Virginia P. Hedmon	1/300
			Eimirien S. Hedmon	1/300
			Linus Hedmon	1/300
			Liana M. Hedmon	1/300
			Eidogidogaiy Hedmon	1/300 (LTO)
Baiti	119	Agoro	Gloria K. Harris	1/32
			Eimoniba Teimiti	1/96
			Martina Ika	1/96
			Eimoniba Teimiti	1/960
			Lucas M. Hedmon	1/960
			Lucia M. Hedmon	1/960
			Juliana E. Hedmon	1/960
			Virginia M. Hedmon	1/960
			Virginia P. Hedmon	1/960
			Eimirien S. Hedmon	1/960
			Linus Hedmon	1/960
			Liana M. Hedmon	1/960
			Eidogidogaiy Hedmon	1/960 (LTO)

G.N.No.277/1983. (Cont'd)

Baiti	148	Mwiruru	As for portion 119 c.l. Baiti.	
Baiti	195	Anakawiduwa		-do-
Baiti	196	Anoror		-do-
Baiti	205	Eatetedij		-do-
Ewa	4	Anora		-do-
Ewa	57	Abaraiami		-do-
Uaboe	56	Yapiyuw		-do-
Anibare	21	Arateng	Gloria K. Harris	1/96
			Eimoniba Teimiti	1/288
			Martina Ika	1/288
			Eimoniba Teimiti	1/2880
			Lucas M. Hedmon	1/2880
			Lucia M. Hedmon	1/2880
			Juliana E. Hedmon	1/2880
			Virginia M. Hedmon	1/2880
			Virginia P. Hedmon	1/2880
			Eimirien S.Hedmon	1/2880
			Linus Hedmon	1/2880
			Liana M. Hedmon	1/2880
			Eidogidogaiy Hedmon	1/2880 (LTO)
Anibare	23	Merubo	As for portion 21 c.l. Anibare.	
Anibare	27	Merubo		-do-
Anibare	343	Arateng		-do-
Ewa	148	Bogeirir		-do-
Anibare	199	Bogetsiw	Gloria K. Harris	1/160
			Eimoniba Teimiti	1/480
			Martina Ika	1/480
			Eimoniba Teimiti	1/4800
			Lucas M. Hedmon	1/4800
			Lucia M. Hedmon	1/4800
			Juliana E. Hedmon	1/4800
			Virginia M. Hedmon	1/4800
			Virginia P. Hedmon	1/4800
			Eimirien S. Hedmon	1/4800
			Linus Hedmon	1/4800
			Liana M. Hedmon	1/4800
			Eidogidogaiy Hedmon	1/4800 (LTO)
Anibare	216	Irotsin	As for portion 199 p.l. Anibare.	
Anibare	218	Atekapara		-do-

G.N.No.277/1983. (Cont'd)

Ewa 166 Anna	Gloria K. Harris	1/192
	Eimoniba Teimiti	1/576
	Martina Ika	1/576
	Eimoniba Teimiti	1/5760
	Lucas M. Hedmon	1/5760
	Lucia M. Hedmon	1/5760
	Juliana E. Hedmon	1/5760
	Virginia M. Hedmon	1/5760
	Virginia P. Hedmon	1/5760
	Eimirien S. Hedmon	1/5760
	Linus Hedmon	1/5760
	Liana M. Hedmon	1/5760
	Eidogidogaiy Hedmon	1/5760 (LTO)

Any person who is dissatisfied with the determination of this estate may appeal to the Supreme Court within 21 days of the publication of this Gazette.

Dated this 9th May, 1983.

(J.A. DAGUAPE),  
VICE CHAIRMAN.

G.N.No.278/1983.

Determination of the Beneficiaries of the Estate of the late Dennis Akaiy of Baiti District

E S T A T E

1. The Nauru Lands Committee has ascertained that the late Dennis Akaiy had been determined by the decisions of the Nauru Lands Committee (or its predecessor the Lands Committee) to be the owner of the following land :-

District	Portion No.	Type of Land	Name of Land	Gazette Notice of Ownership	Share
Anibare	194	p.l.	Atekapara	24/63 38/69	7/80

G.N.No.279/1983.

DETERMINATION OF BENEFICIARIES

2. The Nauru Lands Committee has determined that the beneficiaries of the Estate of the late Dennis Akaiy are :-  
(a) in respect of the land shown in paragraph 1 above.

District	Portion No.	Name of land	Beneficiaries	Share
----------	-------------	--------------	---------------	-------



No. 32

25th May, 1983.

Nauru.

G.N.No.279/1983 (Cont'd)

Anibare      194      Atekapara      Daiwea (Est of)      7/80

NOTE:

The Nauru Lands Committee's decision as to the beneficiaries of the late Dennis Akaiy was published in Gazette No. 14/78 G.N.No.73/1978.

Any person who is dissatisfied with the determination of the Nauru Lands Committee may appeal to the Supreme Court within 21 days of the publication of this notice.

Dated this 10th May, 1983.

J.A. DAGUAPE,  
VICE CHAIRMAN.

# DISTRICT OF ANIBARE

## SCALE 1 : 50'



### CLASSIFICATION OF LAND

BY VIRTUE of the powers vested in me by SECTION 7 of the LANDS ACT 1976, I HEREBY classify the land shown hatched on the plan herein as NON-PHOSPHATE BEARING.

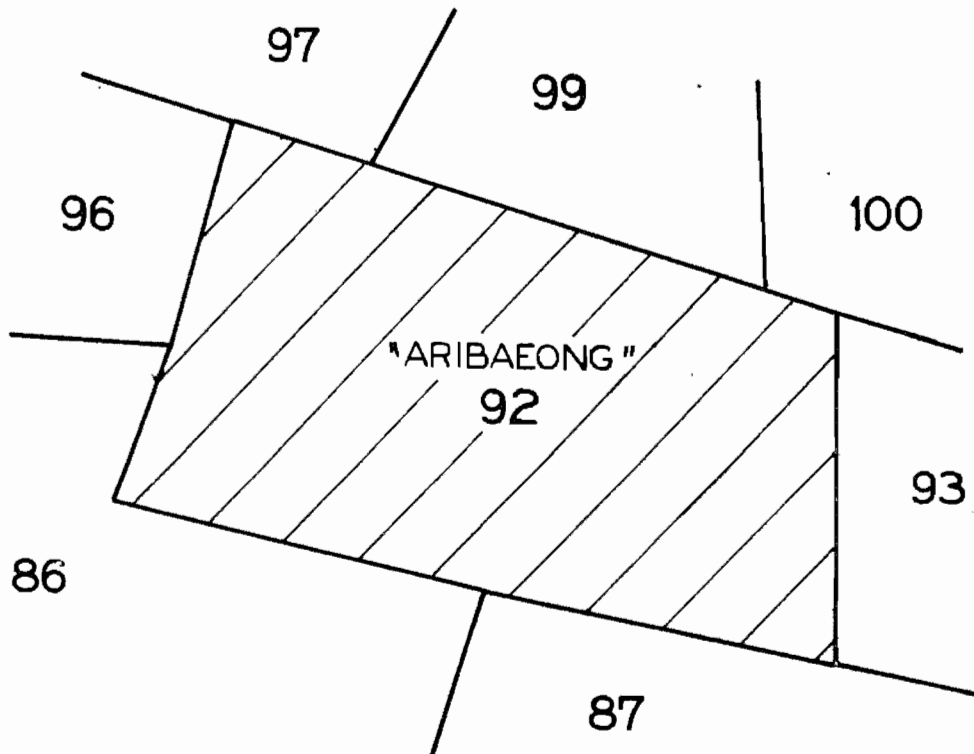

*Hammer DeRobert*  
(HAMMER DEROBURT)

MINISTER  
FOR ISLAND DEVELOPMENT AND INDUSTRY.

# DISTRICT OF MENENG

## SCALE 1:50'

### CLASSIFICATION OF LAND

BY VIRTUE of the powers vested in me by SECTION 7 of the LANDS ACT 1976, I HEREBY classify the land shown hatched on the plan hereunder as NON-PHOSPHATE BEARING.

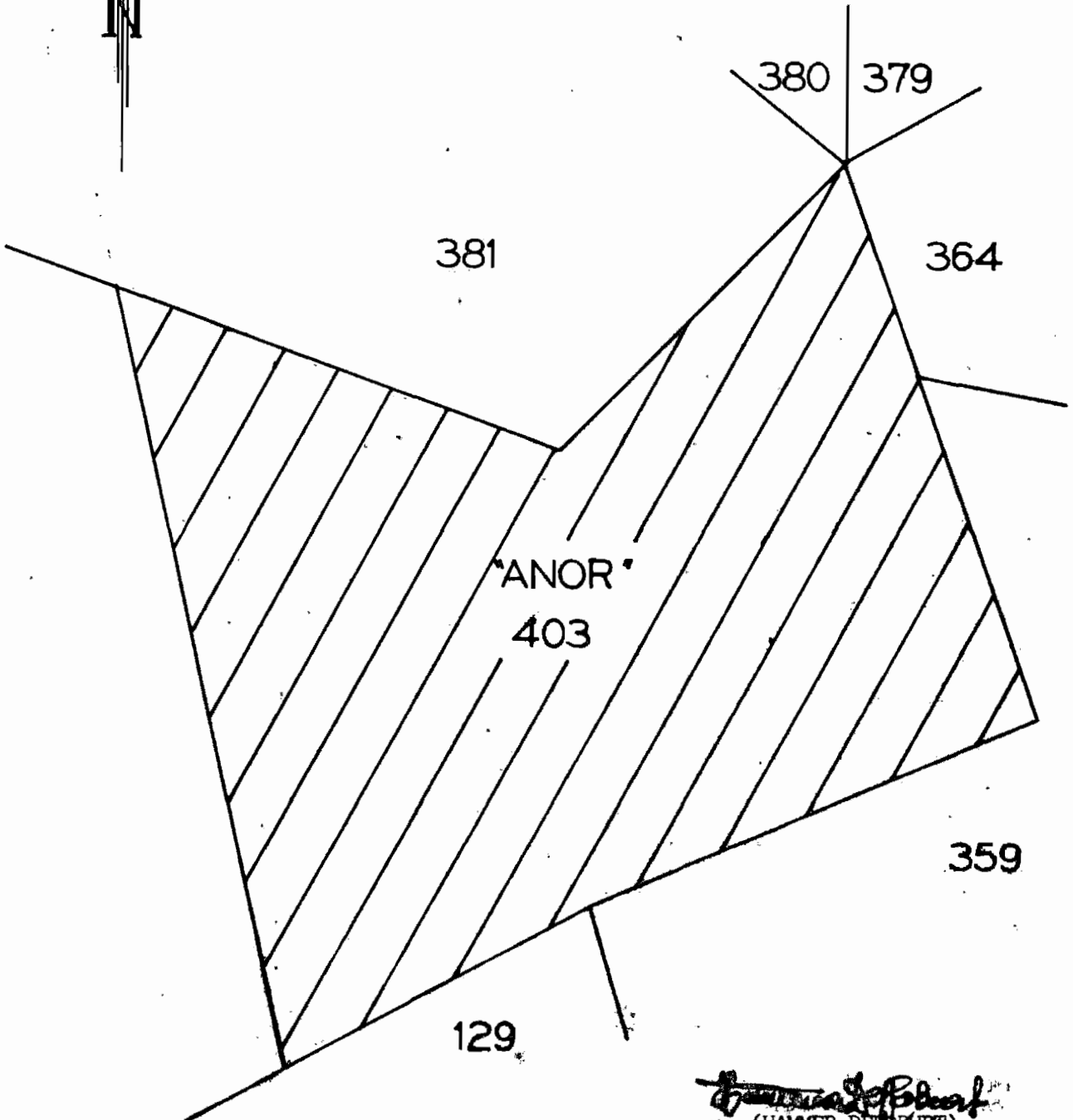

*Hammer Derzurt*  
(HAMMER DERZURT)

MINISTER  
ISLAND DEVELOPMENT AND INDUSTRY.

# DISTRICT OF MENENG

## SCALE 1 : 100'

### CLASSIFICATION OF LAND

BY VIRTUE of the powers vested in me by SECTION 7 of the LANDS ACT 1976, I HEREBY classify the land shown hatched on the plan herein as NON-PHOSPHATE BEARING.

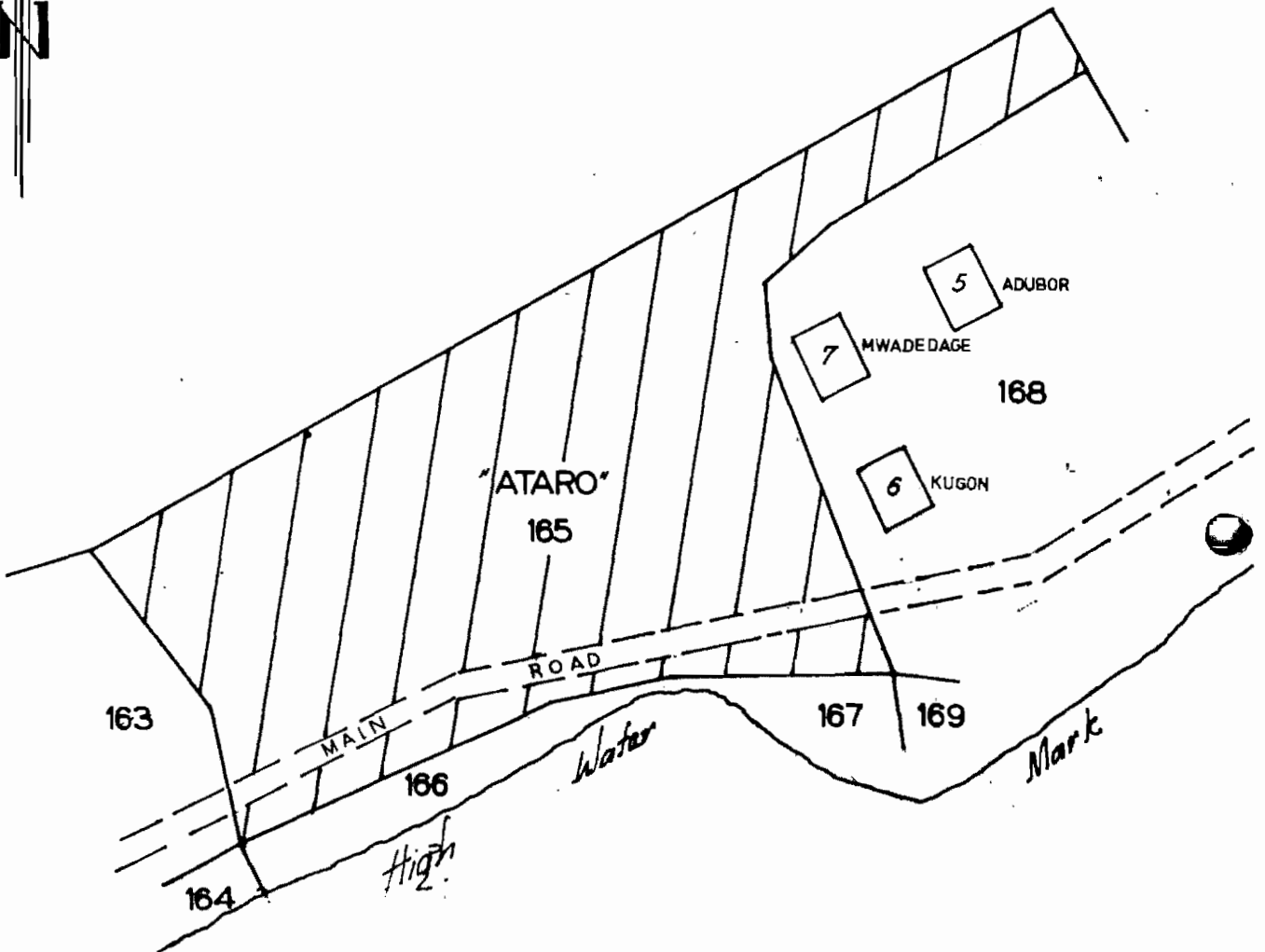

*Francis Robert*  
(HAMMER DEPOSIT)

MINISTER

ISLAND DEVELOPMENT & INDUSTRY.

DISTRICT OF UABOE  
SCALE 1 : 50'

CLASSIFICATION OF LAND

BY VIRTUE of the powers vested in me by SECTION 7 of the LANDS ACT 1976, I HEREBY classify the land shown hatched on the plan herein as NON-PHOSPHATE BEARING.

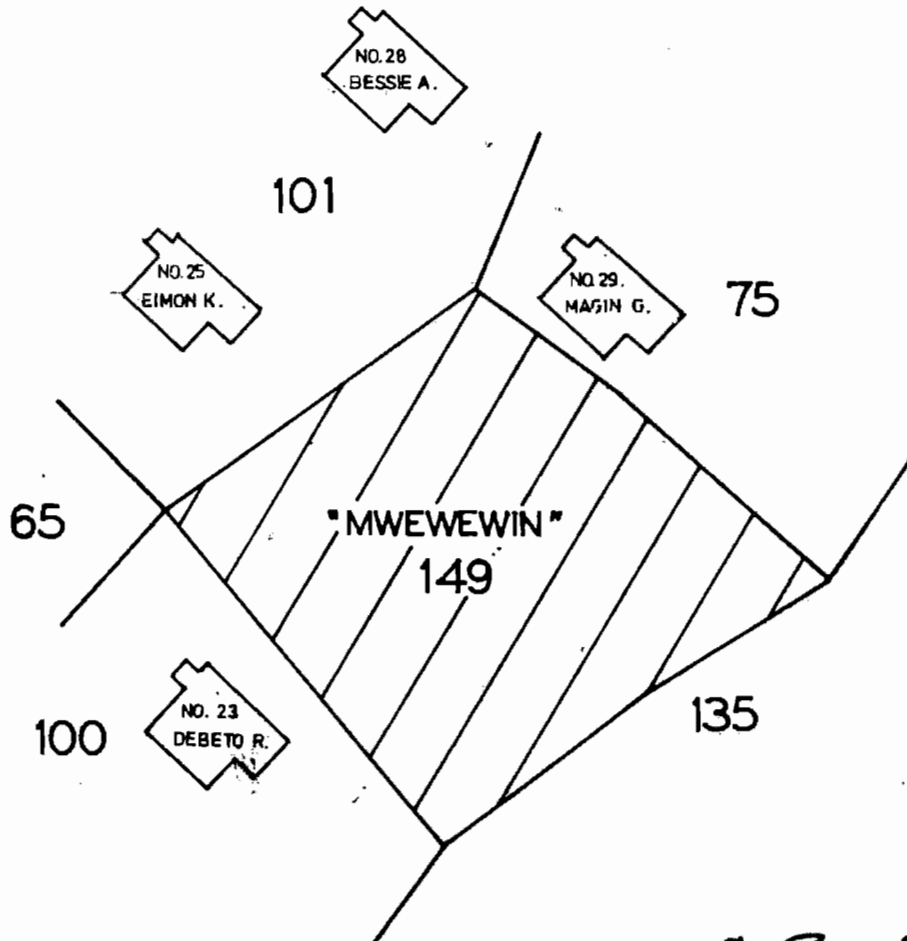
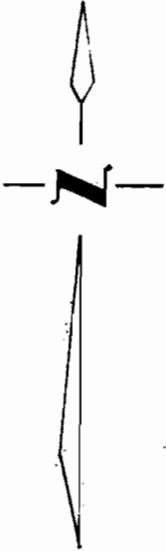

*Lawrence D. Robert*  
(HAMMER DEROURT)

MINISTER  
FOR ISLAND DEVELOPMENT AND INDUSTRY.

DISTRICT OF BAITI  
SCALE 1:50'

CLASSIFICATION OF LAND

BY VIRTUE of the powers vested in me by SECTION 7 of the LANDS ACT 1976, I HEREBY classify the land shown hatched on the plan hereunder as NON-PHOSPHATE BEARING.

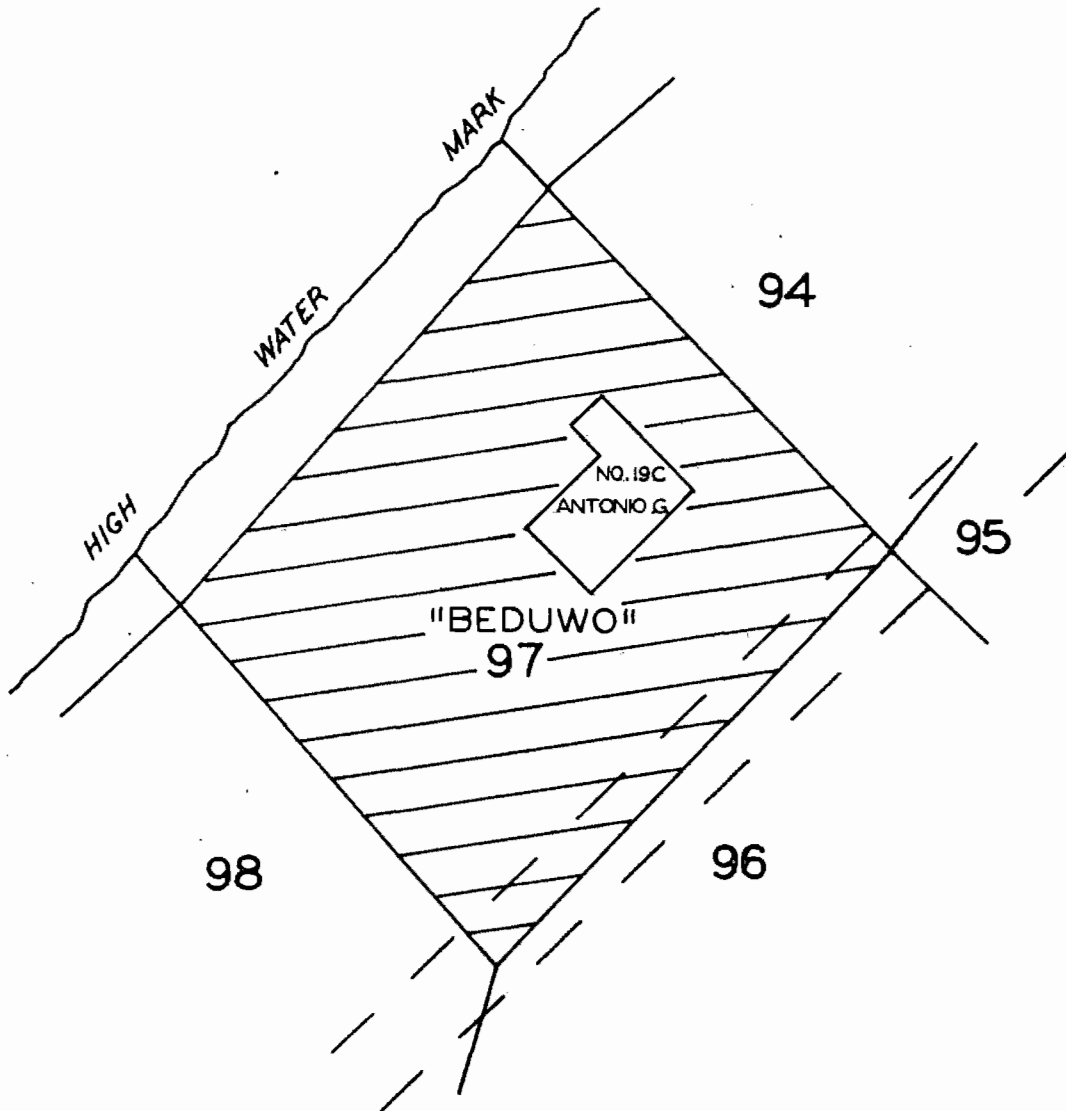

*Hammer Derobert*  
(HAMMER DEROBURT)

MINISTER

ISLAND DEVELOPMENT AND INDUSTRY.

# DISTRICT OF ANABAR

SCALE 1:100'

CLASSIFICATE OF LAND

BY VIRTUE of the powers vested in me by SECTION 17 of the LANDS ACT 1948, I HEREBY classify the land shown hatched on the plan hereunder as NON-FRUITFUL BEARING.

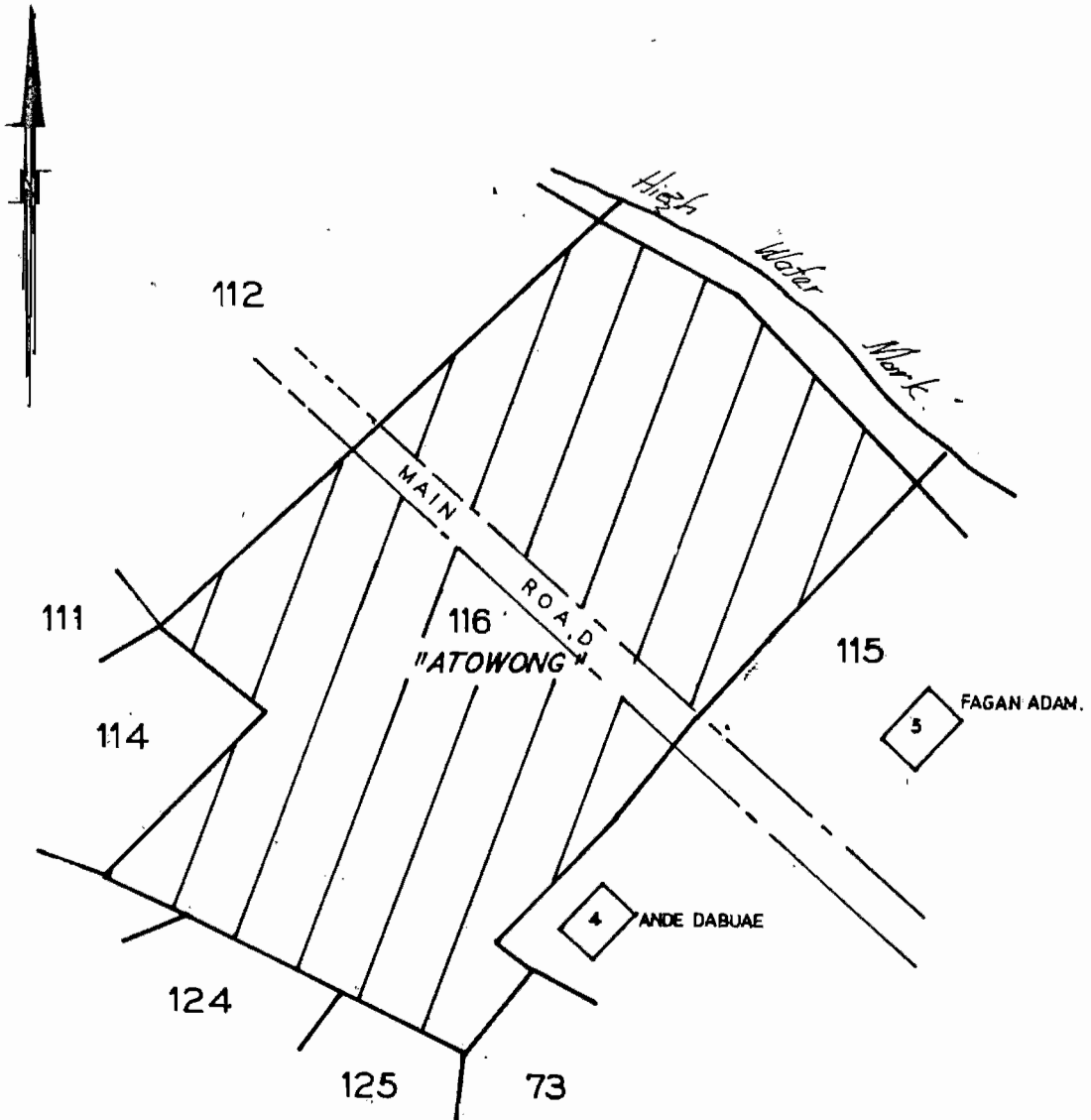

*Hammer DeCourst*  
(HAMMER DECOURST)

MINISTER

ISLAND DEVELOPMENT AND INDUSTRY.

# DISTRICT OF ANABAR

SCALE 1:50'

CLASSIFICATION OF LAND

BY VIRTUE of the powers vested in me by SECTION 7 of the LANDS ACT 1976, I HEREBY classify the land shown hatched on the plan hereunder as NON-PHOSPHATE BEARING.

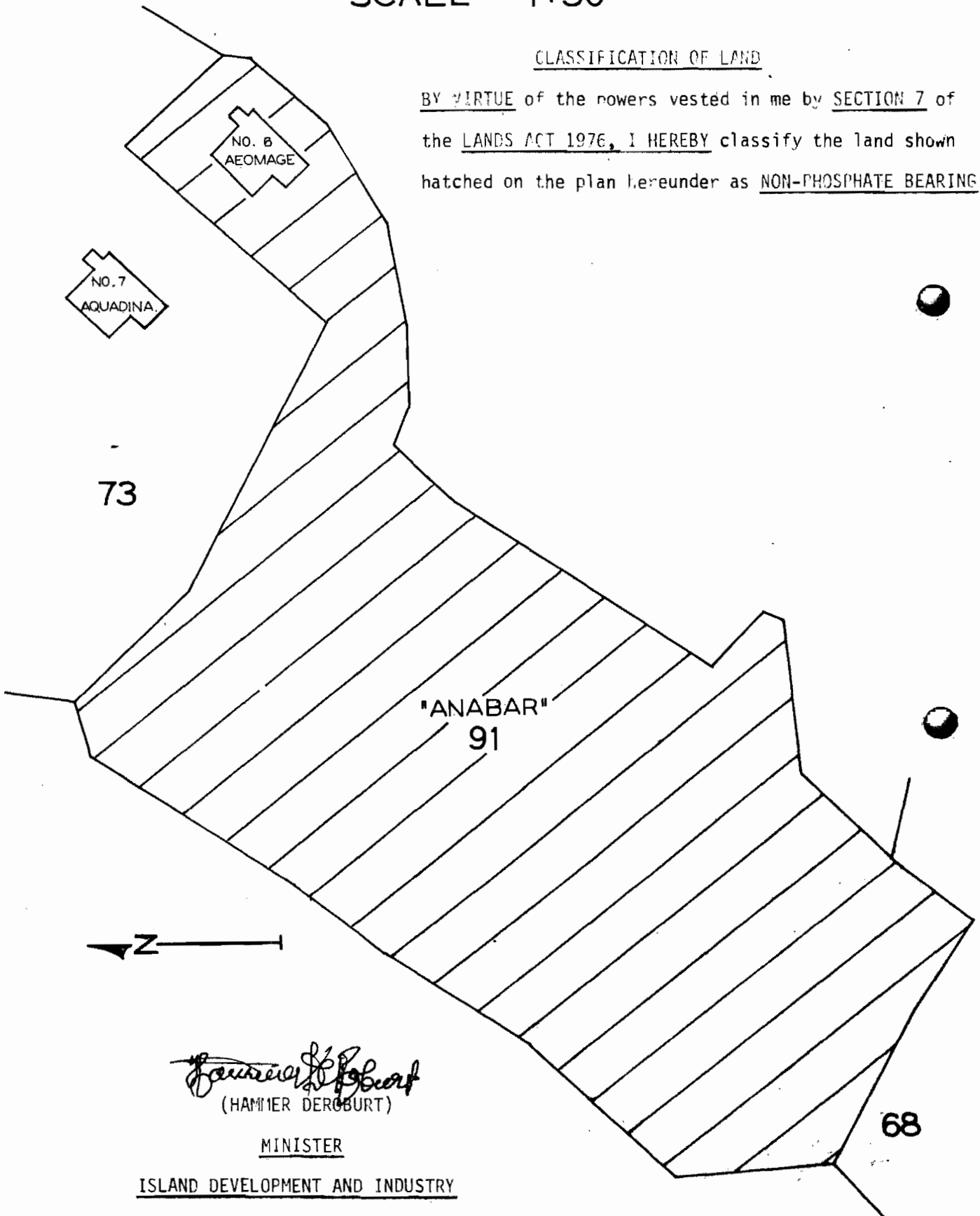

*Hammer Deroburt*  
(HAMMER DEROBURT)

MINISTER

ISLAND DEVELOPMENT AND INDUSTRY



# DISTRICT OF BUADA

## SCALE 1 : 50'

### DECLARATION OF LAND

B. BY ORDER of the GOVERNMENT vested in me by SECTION 10 of the LANDS ACT 1976, I HEREBY classify the land shown attached on the plan hereunder as NON-URBAN RESIDENTIAL.

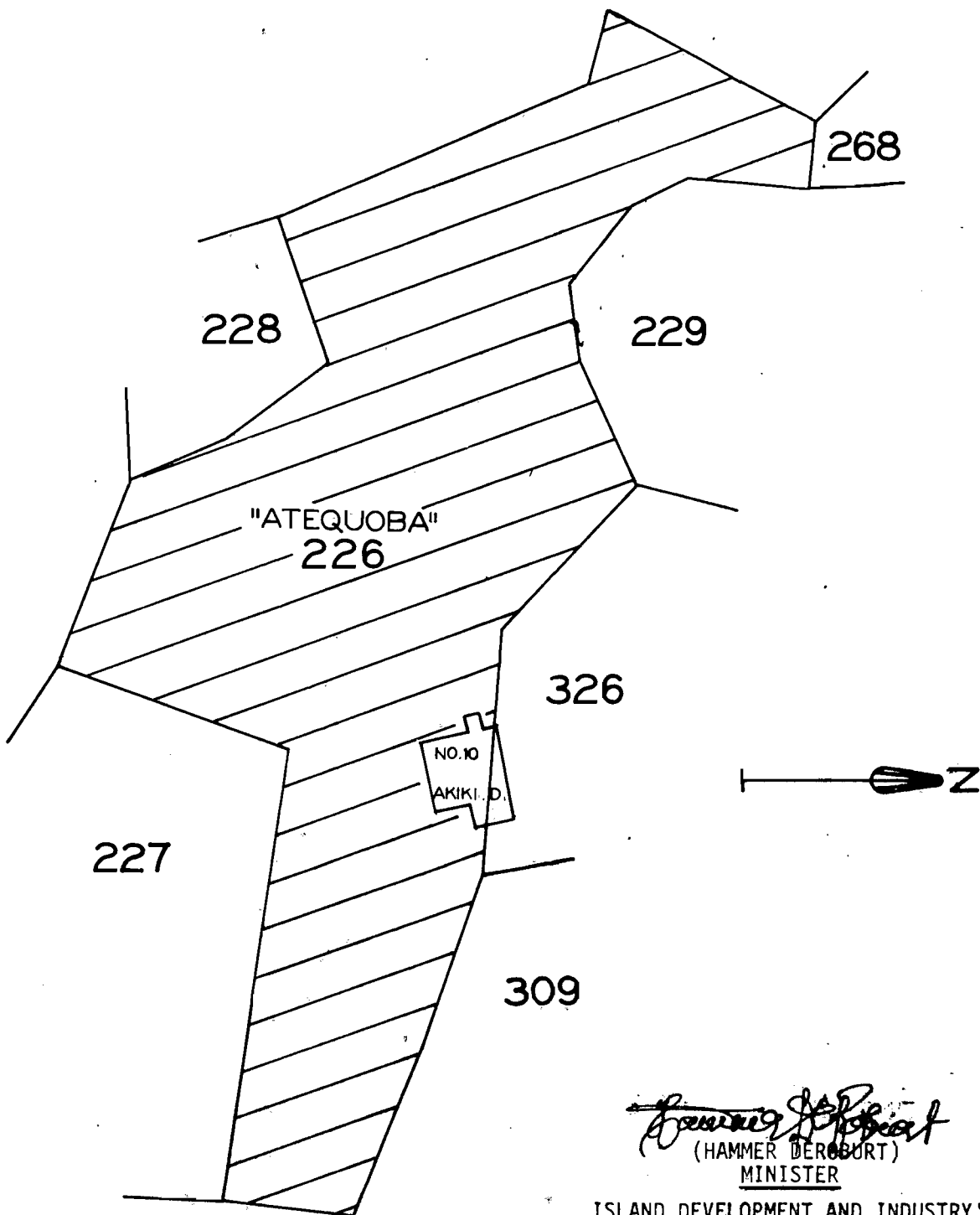

*Hammer Derobert*  
(HAMMER DEROBURT)  
MINISTER

ISLAND DEVELOPMENT AND INDUSTRY: